

GRADALL

XL 2200

HYDRAULIC EXCAVATOR



SPECIFICATIONS

Upperstructure Engine

Cummins 4BT39 diesel, turbocharged, liquid cooled, 4 cycle, 4 cylinder, 239 cid (3.9L), 4.02" bore x 4.72" stroke (102mm x 120mm), 18.5:1 compression ratio.

93 hp (69kW) gross at 2200 rpm, 80 hp (60kW) net at 2200 rpm, 260 ft-lb (352Nm) gross torque at 1500 rpm.

Altitude capability 9850' (3000m), Derate 4% per 1500' (457m) above 9850' (3000m).

Maximum slope: 45°.

12 volt starter, 105 amp alternator, one SAE #C31-S 810 CCA battery, two-stage dry type air cleaner with centrifugal precleaner, ejector valve and service indicator, spin-on oil filter, spin-on fuel filter/water separator.

Fuel tank capacity: 55 gallons (208L).

Hydraulic System

PUMPS

Two load-sensing, axial piston pumps; 0 - 43.5 GPM (0 - 164 L/min) each.

SYSTEM MONITOR

Electronic monitor in cab indicates low hydraulic fluid level, high hydraulic fluid temperature, and condition of return and suction filters.

SYSTEM SPECIFICATIONS

Three double acting cylinders

- 1 boom hoist: 4.75" ID, 3.0" rod (121mm x 76mm), 28" (711mm) stroke,
- 1 tool: 4.5" ID, 2.5" rod (114mm x 63mm), 17.75" (451mm) stroke,
- 1 telescope: 3.5" ID, 2.25" rod (89mm x 57mm), 9.5" (2.87m) stroke.

Four hydraulic motors

Swing, 42 hp (31kW); tilt, 12.6 hp (9kW); two crawler drives, 76 hp (56kW) each.

Operating pressures

Hoist	3950 psi
Tilt	1800 psi
Swing	2875 psi
Tool	3950 psi
Telescope	3150 psi
Crawler	3950 psi
Pilot system	480 psi

Oil capacity

Reservoir 33 gallons (125L), system 55 gallons (208L). Pressurized reservoir with visual oil level gauges.

Filtration system

10 micron return filter with magnet and 100 mesh strainer in reservoir.

Fin and tube-type oil cooler with thermal by-pass and relief valves.

Pressure-compensated, load-sensing valves with circuit reliefs in all circuits.

Upperstructure Cab

All-weather cab with tinted safety glass windows, skylight, acoustical lining, four-way adjustable operator's seat, filtered fresh air heater and defroster. Front window slides to overhead storage. Rear view mirrors on right and left sides.

Controls

Two hydraulic joysticks (hoist & bucket, telescope & swing), one rocker switch (tilt) control upperstructure. Hydraulic joysticks mounted on arm rests, independently adjustable for individual operator comfort and convenience.

Two foot pedals with handles control crawler steering, travel and brakes; toggle switch for selection of crawler speed range.

Joysticks and pedals are self-centering; when controls are released, power for movement disengages and swing, tilt, and crawler brakes set automatically.

Engine controls

Key operated ignition/starter switch, throttle, hour meter and air cleaner condition indicator. Electronic monitor indicates fuel level, low battery charge, coolant level and lube oil pressure, high coolant temperature, and engine rpm.

Swing

Priority swing circuit with axial piston motor. Planetary transmission.

Swing speed: 0 - 9 rpm.

Swing brake

Automatic swing parking brake, spring-set hydraulic release. Dynamic braking provided by hydraulic system.

Undercarriage

Tractor type crawler with triple grouser heavy-duty pads.

Sealed track links, lubricated and sealed idlers and rollers, hydraulic track tension adjustment, track guides, motor and hose guards, front and rear tow eyes.

Track length: 9'10" (3.0m)

Track pads: 19.7" (500mm) or 23.6" (600mm)

Overall width: 8'2" (2.5m) with 19.7" (500mm) pads
8'6" (2.6m) with 23.6" (600mm) pads

Ground clearance: 18" (457mm)

Crawler Drive

Dual range high torque piston motor, 76 hp (56kW), powers each track. Three-stage planetary drive with integral speed limiting valve and automatic spring set/hydraulic release wet disc parking brake.

Travel speed on flat, level surface: mph (km/hr):

Speed Selector	MPH (km/h)
High	3.44 (5.53)
Low	2.34 (3.76)

Travel speed range can be shifted while moving.

Gradeability: 97%.

Drawbar pull: 18,800 lbs. (83kN)

Individual track control. Tracks counter-rotate to pivot machine around on centerline.

Electronically operated travel alarm signals crawler movement in either direction.

Weight

Approximate working weight with 36" (914mm) bucket, fuel tank half full:

	19.7" Pads (500mm)	23.6" Pads (600mm)
Weight	26,615 lbs. (12,072 kg)	26,990 lbs. (12,242 kg)
Bearing Pressure	6.86 psi (0.48 kg/cm ²)	5.8 psi (0.41 kg/cm ²)

Rated bucket breakout force: 17,030 lbs. (75.8)

Rated boom force: 17,780 (79.2 kN).

GRADALL XL 2200 CRAWLER RATED LIFT CAPACITY OVER END OR SIDE: LBS. (KG)

LOAD POINT HEIGHT		LOAD RADIUS				
		Minimum Radius	10' (3.0m)	15' (4.6m)	20' (6.1m)	Maximum Radius
Above Ground Level	15' (4.6m)	3095 @ 16'1" (1405 @ 4.9m)				2460 @ 18'7" (1115 @ 5.7m)
	10' (3m)	7250 @ 10'8" (3290 @ 3.3m)		4365 (1980)	2610 (1185)	2435 @ 20'8" (1105 @ 6.3m)
	Boom Level 6'7" (2m)	7035 @ 11'11" (3190 @ 3.6m)		4800 (2175)	2815 (1280)	2470 @ 21'4" (1120 @ 6.5m)
	5' (1.5m)	7015 @ 12'0" (3185 @ 3.7m)		4880 (2215)	2865 (1300)	2495 @ 21'4" (1130 @ 6.5m)
At Ground Level		6880 @ 10'9" (3120 @ 3.3m)		4515 (2050)	2785 (1260)	2595 @ 20'9" (1175 @ 6.3m)
Below Ground Level	5' (1.5m)	2850 @ 6'5" (1295 @ 1.9m)	4480 (2035)	3525 (1600)		2680 @ 18'8" (1215 @ 5.7m)
	10' (3m)	1635 @ 7'9" (745 @ 2.4m)	2460 (1115)			2520 @ 14'4" (1140 @ 4.4m)

CAUTION: All rated loads are based on the machine being stationary and level on a firm supporting surface. For safe working loads, the user is expected to make due allowance for his particular job conditions, such as soft or uneven ground, out of level conditions, side loads, hazardous conditions, experience of personnel, etc. The operator and other personnel should fully acquaint themselves with the Operator's Manual furnished by the manufacturer before operating this machine, and rules for safe operation of equipment should be adhered to at all times.

The above loads are in compliance with SAE Standard J1097 Nov88. They do not exceed 87% of hydraulic lifting capacity or 75% of tipping capacity.

All loads with an asterisk (*) indicate the load is limited by tipping rather than hydraulic capacity. The rated lift capacity is based on the machine being equipped with 3200 lbs. (1450kg) counter-weight, 23.6" (600mm) or 19.7" (500mm) tracks, and 8025-6002 36" (914cm) excavating bucket weighing 700 lbs. (318kg). For other buckets adjust the listed capacities as follows:

- 8025-6001 60" (1.5m) ditching - subtract 150 lbs. (68kg)
- 8025-6003 30" (762mm) excavating - subtract 85 lbs. (39kg)
- 8025-6004 24" (610mm) excavating - subtract 155 lbs. (70kg)
- 8025-6005 18" (457mm) excavating - add 250 lbs. (113kg)
- 8025-6006 30" (762mm) pavement removal - subtract 329 lbs. (149kg)
- 8025-6012 60" (1.5m) ditching constant radius - subtract 125 lbs. (57kg)

The load point is located on the bucket pivot point, including loads listed for maximum radius. Do not attempt to lift or hold any load greater than these rated values at specified load radii and heights. The weight of slings and any auxiliary lifting devices must be deducted from the rated load to determine the net load that may be lifted.

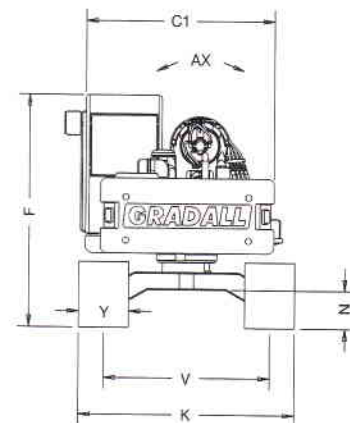
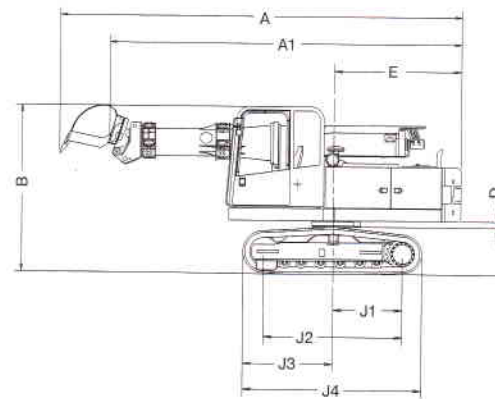
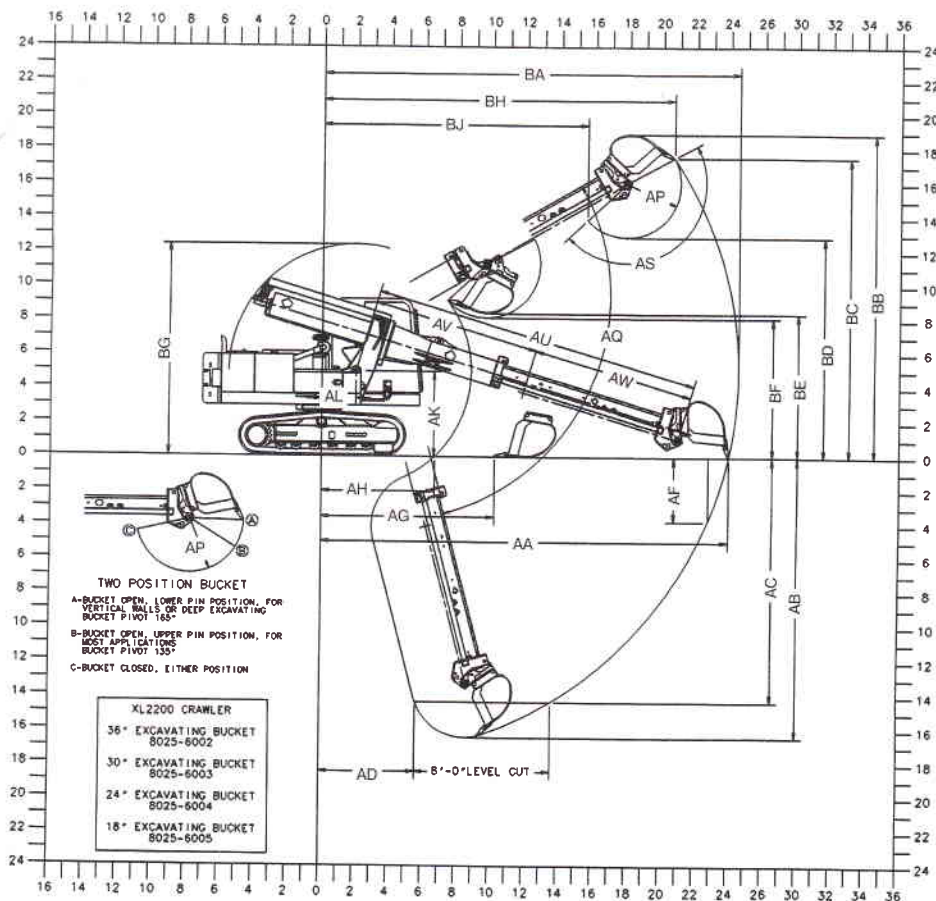

Shown with 8025-6002 36" (914mm) excavating bucket

- A** Overall length with bucket: 22'1" (6.7)
- A1** Overall length without bucket: 19'4" (5.9)
- B** Overall height with bucket: 9'3" (2.8)
- C1** Width of upperstructure: 7'5" (2.3)
- D** Minimum clearance, upperstructure to undercarriage: 3" (76mm)
- E** Swing clearance, rear of upperstructure: 7'0" (2.1)
- F** Top of cab to groundline: 9'3" (2.8)
- G** Clearance, upperstructure to groundline: 35" (889mm)
- J1** Axis of rotation to centerline of drive sprockets: 3'10" (1.2)
- J2** Nominal distance between centerlines of drive sprockets and idlers: 7'7" (2.3)
- J3** Axis of rotation to end of track assembly: 5' (1.5)
- J4** Nominal overall length of track assembly: 9'10" (3.0)
- K** Width of crawler (standard): 8'6" (2.6)
Width of crawler (optional): 8'2" (2.5)
- N** Ground clearance (per SAE J1234): 18" (457mm)
- V** Track gauge, roller centerline to roller centerline: 6'6" (2.0)
- Y** Width of crawler track assembly (standard): 23.6" (600mm)
Width of crawler track assembly (optional): 19.7" (500mm)
- AA** Maximum radius at groundline (165° pivot): 24'0" (7.3)
- AB** Maximum digging depth: 16'5" (5.0)
- AC** Maximum depth for 8' level cut: 14'4" (4.4)
- AD** Minimum radius for 8' level cut at depth "AC": 5'8" (1.7)
- AF** Maximum depth of vertical wall which can be excavated: 3'9" (1.1)
- AG** Minimum level cut radius with bucket flat on groundline: 10'4" (3.1)
- AH** Minimum radius at groundline: 6'10" (2.1)
- AK** Boom pivot to groundline: 4'11" (1.5)
- AL** Boom pivot to axis of rotation: 24" (609mm)
- AP** Bucket tooth radius: 3'2" (965mm)
- AQ** Boom pivot angle: 30° Up & 75° Down
- AS** Bucket pivot angle: 135° & 165°
- AU** Maximum telescoping boom length (boom pivot to bucket pivot): 19'4" (5.9)
- AV** Minimum telescoping boom length (boom pivot to bucket pivot): 9'11" (3.0)
- AW** Telescoping boom travel: 9'5" (2.9)
- AX** Bucket tilt angle: 360° (continuous)
- BA** Maximum radius of working equipment (165° pivot): 24'6" (7.5)
- BB** Maximum height of working equipment: 18'11" (5.8)
- BC** Maximum bucket tooth height: 17'6" (5.3)
- BD** Minimum clearance of bucket teeth with bucket pivot at maximum height: 12'10" (3.9)
- BE** Minimum clearance of fully curled bucket at maximum boom height (165° pivot): 8'5" (2.6)
- BF** Minimum clearance of bucket teeth at maximum boom height: 8'2" (2.5)
- BG** Maximum height of working equipment with bucket below groundline: 12'8" (3.9)
- BH** Radius of bucket teeth at maximum height (165° pivot): 20'8" (6.3)
- BJ** Minimum radius of bucket teeth at maximum bucket pivot height (165° pivot): 15'7" (4.7)

Metric units are meters (m) unless noted

Machines shown may have optional equipment

Optional Equipment

Work lights: 2 floodlights on boom cradle, 4 floodlights on cab, 2 floodlights on left front shrouding.

Windshield washer and wiper.

Vandalism protection kit: Lexan cab windows, locking reservoir cap and sight gauge cover; locking engine hood, fuel cap and battery box.

Spark arrestor.

Revolving beacon.

Cold start package for engine: includes ether start kit and additional battery.

Air conditioning.

Inside hose trough with additional hosing and piping for pneumatic or hydraulic powered attachments.



Cu.
yd. m³

8025-6005 18" (457mm) Excavating bucket	3/16	.15
8025-6004 24" (610mm) Excavating bucket	1/4	.31
8025-6003 30" (762mm) Excavating bucket	3/8	.29
8025-6002 36" (914mm) Excavating bucket	1/2	.38



8025-6006 30" (760mm)
Pavement removal bucket

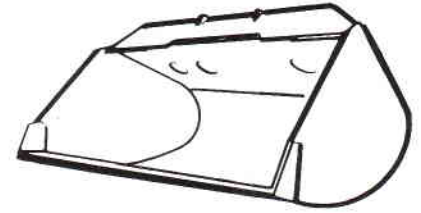

Cu.
yd. m³

8025-6001 60" (1.5m) Ditching bucket	3/4	.61
8025-6012 60" (1.5m) Constant radius ditching bucket	5/8	.53

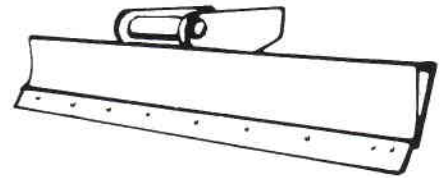

8025-6013 8' (2.4m) Grading blade with bolt on edge.

ATTACHMENTS

Buckets fabricated of steel plate, with high strength, low alloy cutting edges and wear strips. Standard attachments available for wide range of applications. Capacities shown are in heaped cu. yd.

TWO-POSITION BUCKET

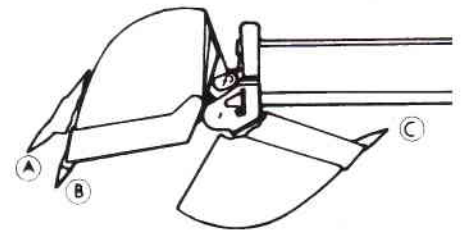

A: Bucket open, lower pin position, for vertical walls or deep excavating. Bucket pivot 165°.

B: Bucket open, upper pin position, for most applications. Bucket pivot 135°.

C: Bucket closed, either pin position.

It is Gradall Policy to continually improve its products. Therefore designs, materials and specifications are subject to change without notice and without incurring any liability on machines already sold. Machines shown may have optional equipment.

GRADALL®

406 Mill Ave. SW, New Philadelphia, Ohio 44663
Phone (330) 339-2211 FAX (330) 339-8468
www.gradall.com